

Bicycle Quick Release Usage Survey

TEST START DATE: June 14th, 2008

LOCATION: Cambridge River Festival, Cambridge, Massachusetts, USA

SURVEY CONDUCTED BY: CLIX Systems, Inc.

Abstract

The use of a quick release as a mechanism for fastening the front wheel to a bicycle has gained widespread use since its invention in 1927. Despite rising popularity, it is questionable how many users know how to correctly operate a bicycle front wheel quick release. To determine what percentage of people riding bicycles equipped with a front wheel quick release know how to correctly operate the quick release, a two part survey was administered to participants at the Cambridge Riverfest in Cambridge Massachusetts. Results showed that over half (56%) of the participants surveyed were not able to demonstrate correct operation of a quick release mechanism, despite a majority of participants claiming to be intermediate and experienced cyclists.

Bicycle Quick Release Usage Survey

The use of a quick release mechanism as a means for securing the front wheel of a bicycle to the fork was propagated by Tullio Campagnolo in 1927. The original intent of the traditional quick release was to give bicycle racers the ability to remove and install the front wheel of a bicycle in a more efficient manner. Prior to the invention of the quick release, the popular method for attaching the front wheel was a nut and bolt system which required the use of specific tools.

When used correctly, as detailed by the Shimano Inc. bicycle quick release manual (Appendix A), standard quick releases function as designed, securing the front wheel to the fork. Correct use depends on numerous factors including tightening torque (5 – 7 N-m [43 – 65 in. lbs.] as defined in Appendix A) and lever positioning. When any aspect of the quick release use process is performed incorrectly, the potential for the system to fail during riding increases.

The purpose of this study is to determine the percentage of owners of bicycles with front wheel quick releases who are able to correctly use a standard quick release to secure their bicycle's front wheel where correct use is determined by the Shimano Inc. quick release operation manual (Appendix A). This study will break down quick release use across rider experience and sex. The relationship between rider experience level and quick release operation will be examined for consistency between groups.

Method

Participants

Survey participants consisted of general attendants at the Cambridge River Festival in Cambridge, Massachusetts. Participants were both male (n=127) and female (n=70) of various ranges in cycling experience.

Participants were divided into beginner, intermediate, and experienced riders. Of these designations 8% of participants identified themselves as beginners, 50% as intermediates and 42% as experienced (Table1). Between sexes, 5% of males identified themselves as beginners, 46% as intermediates and 49% as experienced whereas in the female distribution, 14% of participants identified themselves as beginners, 59% as intermediates, and 27% as experienced. These measures of bicycling experience were self-reported and were not verified by survey administrators.

All survey participants were required to own a bicycle with a front wheel quick release. Thus, two groups of people participated - those who approached the survey site with a bicycle with a front wheel quick release and those who claimed to have a bicycle with a front wheel quick release at home. Ownership of a bicycle with a front wheel quick release served as a standardization method for participant experience with the mechanism examined in this study.

Survey participation was compensated with bottled water and a free entry in a bicycle related raffle. Participants were self-selecting, opting on their own to approach the administrators and inquire about the survey. Compensation and qualifications were clearly advertised. All participants were informed of the survey process and consented to participation. Subjects were notified that they were free to cease participation at any time during the course of the survey.

Apparatus

The study was conducted at the Cambridge River Festival located in Cambridge, MA, USA. The study consisted of paper surveys (Appendix B) detailing bike model owned, ride frequency, type of rider, sex, and age. The survey administrators consisted of one person who would greet the participant and three others who would oversee the physical demonstration of quick release use. Each administrator was pre-qualified to determine correct use of all styles of bicycle quick release and agreed to follow correct use requirements as detailed in the Shimano, Inc. manual for bicycle quick release operation (Appendix A). The physical test site was based around a single table with an open air tent overhead. On the tent, signs were posted alerting the general public of free water and a chance to enter the raffle upon survey participation. The test site was situated directly on the main corridor of the festival.

To compensate for bicycle owners who did not have their bicycle at the location of the survey, two bicycles were set up with front wheel quick releases

for use in the demonstration section of the survey. The quick releases used on the demonstration bicycles were of common function and design.

Procedure

As participants approached the test site, they were greeted by an administrator who checked if the bicycle they were riding had a front wheel quick release. If the participant was on foot, the greeter would inquire if the participant owned a bicycle with a front wheel quick release. If the participant owned a bicycle with a front wheel quick release, the greeting administrator would describe the survey to them as “a two part survey regarding bicycle quick release use”. They were then told that the first part of the survey would be written and the second part would consist of a personal demonstration of quick release use. If the participant agreed to take the survey, they were led to the table where they would fill out the paper survey (Appendix B).

Upon completion of the survey, participants with their bicycle present were instructed to take the written survey to one of the administrators overseeing the physical demonstration. Participants who did not have their bicycle present followed identical instructions with a provided demonstration bike. All participants in the later group were asked if they were familiar with the quick release system on the demonstration bike. Administrators would receive all participants individually, examining the bike at hand for current state of installation. Once current state was noted, the administrator would remove the front wheel of the

bicycle and instruct the participant to correctly reinstall it. Once this instruction was given, the administrator would passively observe the participant's actions noting significant failures in the process of installing the wheel. As the purpose of the study was to measure quick release use, the administrators were instructed to disregard any incorrect use that did not directly involve the quick release (ex: reinstalling the brakes). Participants were allowed to have as much time as they desired to complete the task at hand. The administrators would approach the participants when they signaled they were done with the task.

Once the participant indicated they were done, the administrator would physically inspect the quick release, checking if it was installed at the correct tension level (the administrator would unlock the quick release lever and then re-activate the cam to see if closing the lever at the tension level set by the participant was correct). If the participant's installation was deemed correct, they were thanked for their participation and given their compensation. If the participant's installation was deemed incorrect, the administrator would educate the participant on the proper method for installing a bicycle quick release, thank them and provide the compensation. Records of correct and incorrect installation were marked on the survey sheet and filed by the administrator. Survey data collected was kept confidential and only shared with the primary administrators of the study.

Results

Analysis of the data yielded that of the total number of participants riding bicycles with a quick release (n=197), 56% could not demonstrate how to correctly operate a bicycle front wheel quick release (Table 2). Of the participants who were unable to operate a quick release correctly (n=110), 56% were male and 44% were female. Within the male/female groups, 49% of men and 69% of women incorrectly operated a bicycle quick release (Table 3).

Taking self-reported experience into account 56% of beginners, 65% of intermediates, and 45% experienced riders could not demonstrate correct operation of a quick release (Table 4). Analyzing this trend by sex yields 66% of male beginners, 52% of male intermediate, and 44% of experienced men incorrectly operating their front wheel quick release. For females, 50% of beginners, 83% of intermediates and 47% of experienced women incorrectly operated their front wheel quick releases. For clarity, results have been rounded to the nearest percentage throughout this report.

Discussion

In this study of quick release use, over half (56%) of the surveyed participants were unable to correctly operate a bicycle front wheel quick release with 49% of sampled males and 69% of sampled females failing at the task. At the same time, an increasing percentage of bicycles being sold in the marketplace are equipped with traditional quick releases. It is noted that cyclists may be unaware of their lack of knowledge in correct quick release installation.

This is evidenced by the break down between self-reported experience levels (Table 1). Ninety-two percent of participants identified themselves as intermediate and experienced riders. By identifying with these categories riders are thus displaying confidence that they are knowledgeable regarding their bicycles and operation of components such as the quick release correctly. The results indicate that this is a false assumption on behalf of the participants. Intermediates as a group had the highest failure rate amongst those surveyed. It is also noted that the female group was more likely to incorrectly use a quick release than the male group (Table 3).

Conclusion

Study results indicate that more than half of the general population cannot operate a traditional quick release correctly with men fairsing somewhat better than women. Based on the lack of consistency found between self-reported experience level and correct quick release use, a strong correlation between self-reported riding experience and the correct operation of a front wheel quick release was not demonstrated. Thus, despite 92% of participants surveyed feeling confident enough in their cycling abilities to report themselves as either intermediate or experienced riders, over half failed to correctly operate a front wheel quick release. This means that the average rider considers him or herself knowledgeable, but cannot reattach their front wheel in a safe manner. Based on this information it may be concluded that there exists a usage gap between the

mechanical abilities of the average rider and the traditional quick release used to fasten the front wheel onto many bicycles currently offered in the marketplace.

Table 1

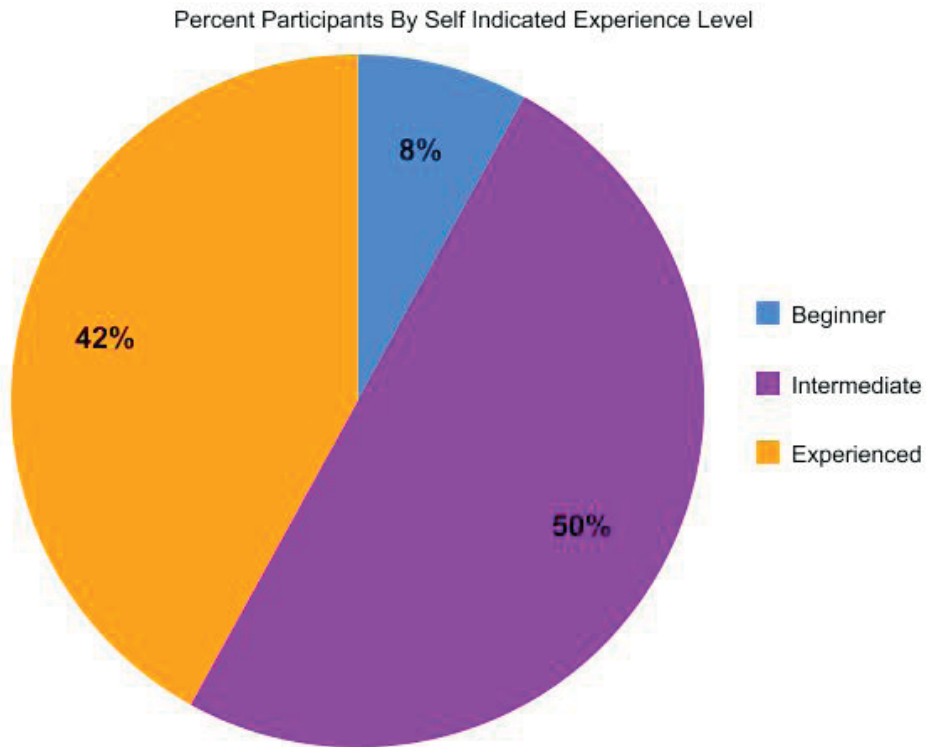

Table 2

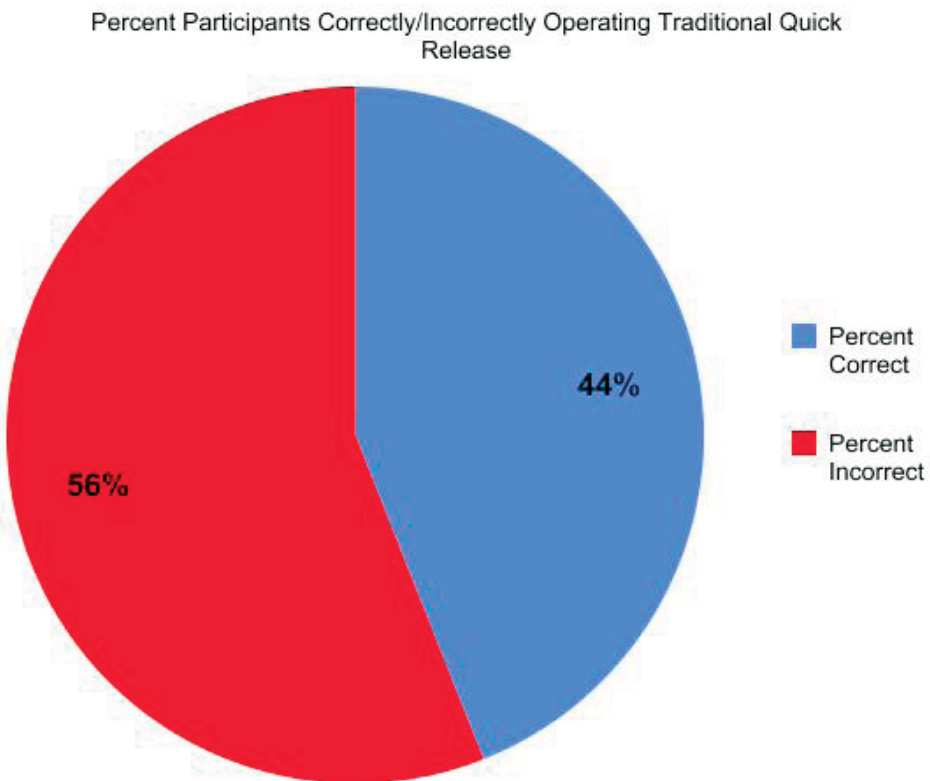

Table 3

Percent of Men and Women Incorrectly Operating Traditional Quick Release

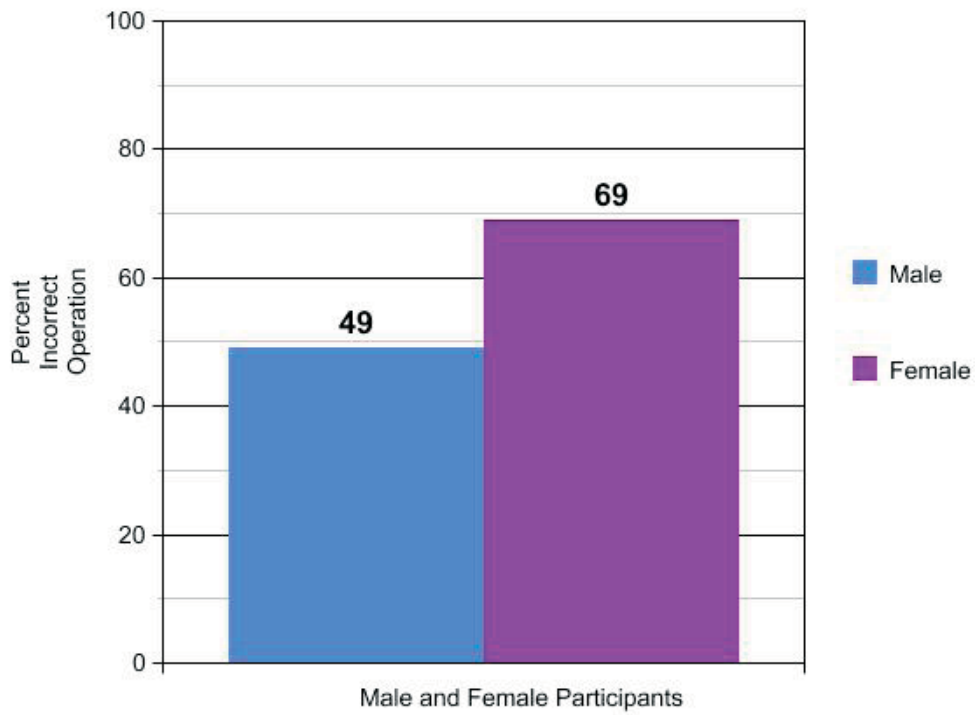

Table 4

Percent Participants Incorrectly Operating Traditional Quick Release by Self Determined Experience Level

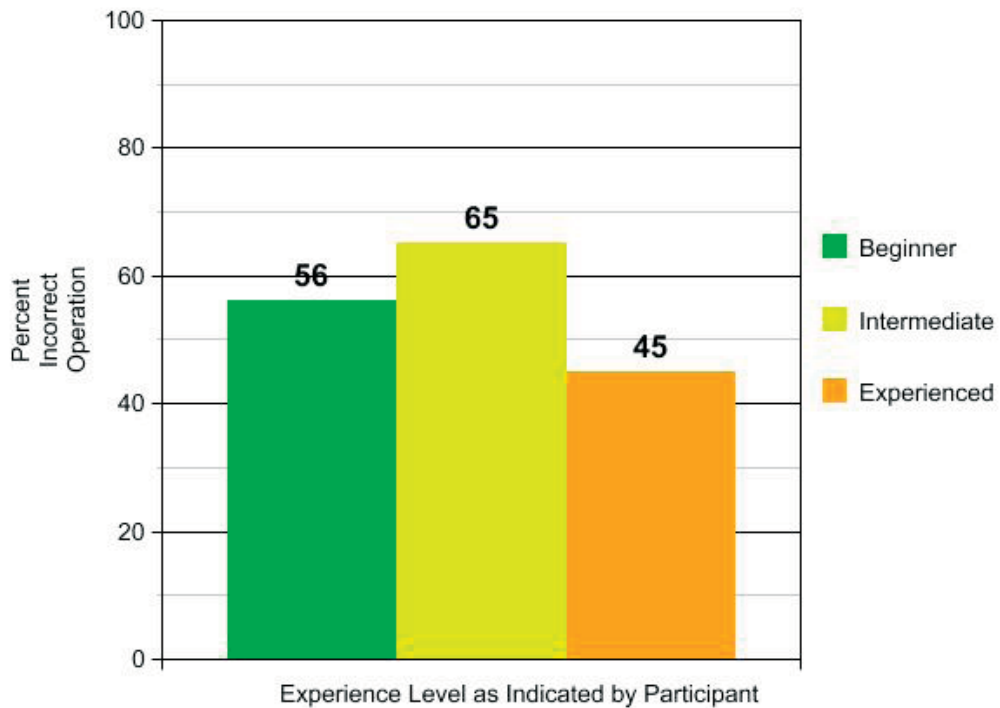

Table 5

		Correct		Incorrect		Total
Male- Beginner		2		4		6
Male-Intermediate		28		30		58
Male-Experienced		35		28		63
Male - Total		65		62		127
Female- Beginner		5		5		10
Female-Intermediate		7		34		41
Female- Experienced		10		9		19
Female - Total		22		48		70
Total		87		110		197*

* Note: 3 Participants were discounted as the second portion of the survey was incomplete.

** Tables 1 - 4 are based on the data from table 5 rounded to the nearest whole number.

General Safety Information

⚠ WARNING

- This wheel is equipped with a quick release hub to facilitate installation and removal. Failure to properly install the quick release hub (wheel) onto your bicycle may cause the wheel to become detached from the bicycle while you are riding and result in serious bodily injury.
- Use a front fork which is equipped with a wheel retention mechanism.
- **BEFORE USE, CAREFULLY READ THE QUICK RELEASE SERVICE INSTRUCTIONS IN YOUR OWNER'S MANUAL. IF YOU HAVE ANY QUESTIONS, ASK YOUR DEALER. IMPROPER HUB INSTALLATION CAN RESULT IN SERIOUS BODILY INJURY.**
- Read these Technical Service Instructions carefully, and keep them in a safe place for later reference.

⚠ CAUTION

- Be sure to operate the quick release lever by hand only. Never use any other tool such as a hammer to tighten the quick release lever, as this could cause damage to the lever.

Note

- Parts are not guaranteed against natural wear or deterioration resulting from normal use.
- For maximum performance we highly recommend Shimano lubricants and maintenance products.

Technical Service Instructions SI-3000H

Quick Release

■ What is a Quick Release?

It is a mechanism that uses a single quick-release lever operation on the hub to enable the wheel to be easily installed and removed.

■ Quick Release function

When the quick release lever is brought to the closed position, the lever nut moves inward. The force of this clamps the wheel to the frame and holds the wheel securely in place.

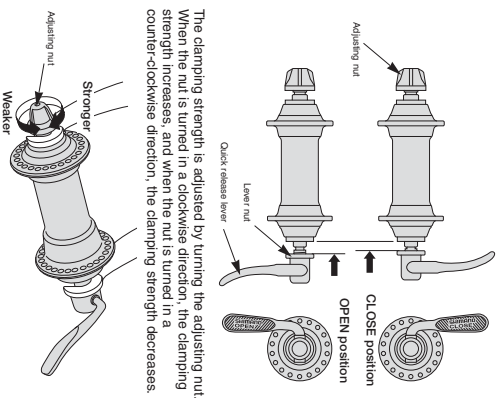

The clamping strength is adjusted by turning the adjusting nut. When the nut is turned in a clockwise direction, the clamping strength increases, and when the nut is turned in a counter-clockwise direction, the clamping strength decreases.

■ Suitable dimensions of the fork end

Be sure to use only fork widths with suitable dimensions.

Front ...
cannot use fork thicknesses less than 4 mm.
(Dura-Ace, 600 Ultegra: not less than 5 mm.)



Rear ...
cannot use fork thicknesses less than 5 mm.
(Dura-Ace, 600 Ultegra: not less than 6 mm.)



■ **Operation method**
The front axle is explained as an example. The rear axle works in the same way.

How to fasten this quick release

1. Move the quick release lever to the OPEN position and set the wheel so it firmly touches the interior of the fork end (See sketch below).

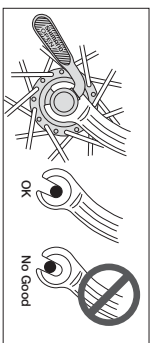
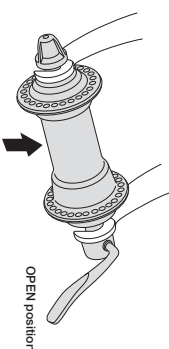

2. Open and close the quick release lever with your right hand while gradually tightening the adjusting nut (located on the opposite side of the hub) with your left hand in the clockwise direction. Continue tightening the nut until you feel resistance with your hand at the point when the lever is parallel to the diagram on the right.

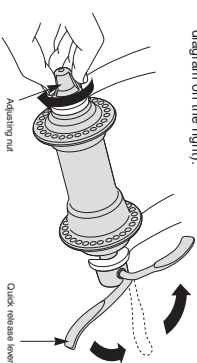

3. Grip the fork with your fingers and use the palm of your hand to close the quick release lever with as much strength as possible. When closed, the quick release lever must be in the "CLOSE" position shown below in the diagram on the right. The side of the lever with the inscription "CLOSE" must be facing away from the wheel, and the lever should be parallel to the fork as shown below in the diagram on the left.

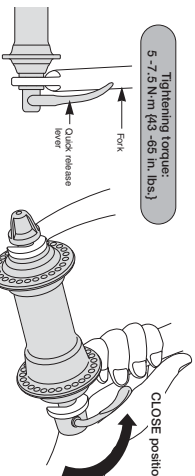

⚠ CAUTION

Never fasten a wheel to a frame by rotating the quick release lever as shown in the diagram on the right. Simply rotating the lever in a circular motion will not fasten the wheel to the frame. Detachment of the wheel as a result of improper hub installation can result in serious bodily injury.



■ Notes

If the quick release lever can be easily pushed to the CLOSE position, this means the clamping strength is insufficient. Return the quick release lever to the position perpendicular to the bicycle frame and again turn the adjusting nut clockwise to increase the clamping strength. Push the quick release lever back to the CLOSE position.

If the clamping strength is adjusted too strong and the quick release lever cannot be pushed to the CLOSE position, turn the adjusting nut in a counter-clockwise direction to reduce the clamping strength. When doing this, do not fully release the adjuster nut. Turn it 1/8 of a revolution, and then try to push the lever to CLOSE to see the maximum clamping strength with which you can push the quick release lever to the CLOSE position.

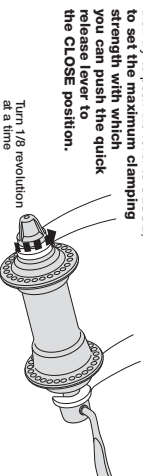

Positioning of the quick release lever

For safety, the quick release lever should be along the bicycle frame when in the CLOSE position.



Removing the wheel

Move the quick release lever from the CLOSE position to the OPEN position, and then remove the wheel.

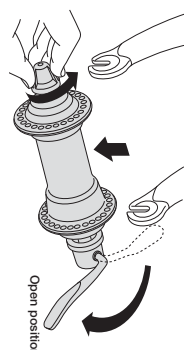

⚠ WARNING

THINGS TO CHECK BEFORE RIDING

1. Always check your quick release hubs before riding to make sure that the wheels are correctly installed on the bicycle frame. This is especially important after you park your bicycle in a public place.
2. Make sure that the quick release levers are pushed fully to the CLOSE position, (the side of the lever with the inscription "CLOSE" must be facing away from the wheel). As shown in the diagram, the lever must be lifted, not rotated.

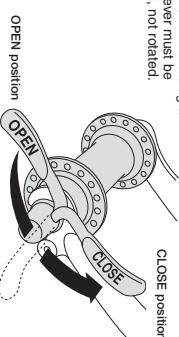

QUICK CHECK

Lift up the bicycle so that the wheel is off the ground, and give the top of the tire a few sharp downward blows as shown in the diagram. The wheel should not be loose or come off. This check does not guarantee that the quick release lever has received adequate tightening torque. If you are uncertain as to whether the quick release is tightened correctly, repeat the installation procedure as explained in "How to fasten this quick release hub" of this service instruction.

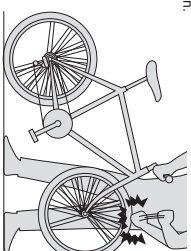

If the quick release will not adjust properly, please contact a professional dealer for advice.

SHIMANO®

These Service Instructions are printed on recycled paper.
SHIMANO AMERICAN CORPORATION
One Mountain View Circle, U.S.A.
SHIMANO EUROPE
Industrieweg 24, NL-6071 CT Tilburg, The Netherlands
SHIMANO INC.
3770 Central Expressway, Fremont, CA 94538, U.S.A.
© Dec. 2002 by Shimano Inc. XBC SHS Printed in Japan

Appendix A

Appendix B

BICYCLE QUICK RELEASE SURVEY For Cyclist Riding Bikes With Quick Releases

Bike Model: _____

Type: Mountain Bike: _____ Hybrid: _____ Road Bike: _____

I Ride: Every Day: _____ Once a Week: _____ Once a Month: _____

Type of Rider: Beginner: _____ Intermediate: _____ Experienced: _____

Male: _____ Female: _____

Age: 10-20 _____ 21-30 _____ 31-40 _____ 41-50 _____ 51-60 _____ 61+ _____

Name: _____

From: _____
City State

FOR OFFICIAL USE ONLY:

Quick Release Type: Side arm/closed _____ Center/open _____

Pre-survey condition: C: _____ I: _____

Operation: C: _____ I: _____ Refd: _____

Operation CAI: _____

Date: _____ Location: _____ Initials: _____ Time: _____